



Mini Cat Racing USA

GII MICRO HYDRO



Instructions

General Layout

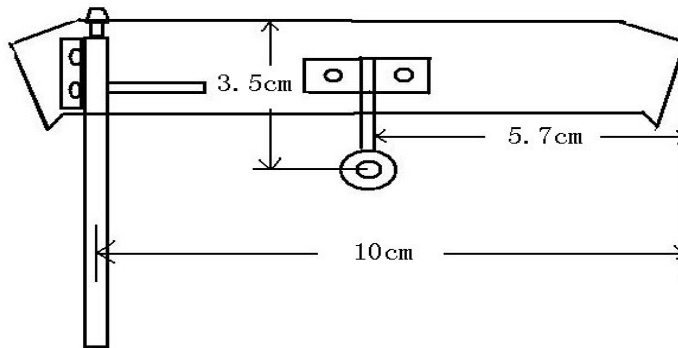

Weight of the boat excluding receiver and battery: 372.5g – 13.14oz.

Length: 380mm – 14.96”

Width: 200mm – 7.87”

Height: 80mm – 3.14”

Batteries: NiMh Nickle Metal Hydride 9.6V 8 cell 2/3A 1500 mAh

Lithium Polymer 15C-25C 11.1V 1500mAh-2200mAh. **Battery physical size is important so it will fit! 3/4-1” thick, 1-3/8” wide, length doesn’t matter.**

ESC: 40A continuous/ 50A for 30 seconds. 5-15 Volts, 6-12 NiMh cells, 2-3 Lipo cells. **Standard water cooled.**

Motor: Tenshock Viper 3200KV 4 pole. **Water cooled.**

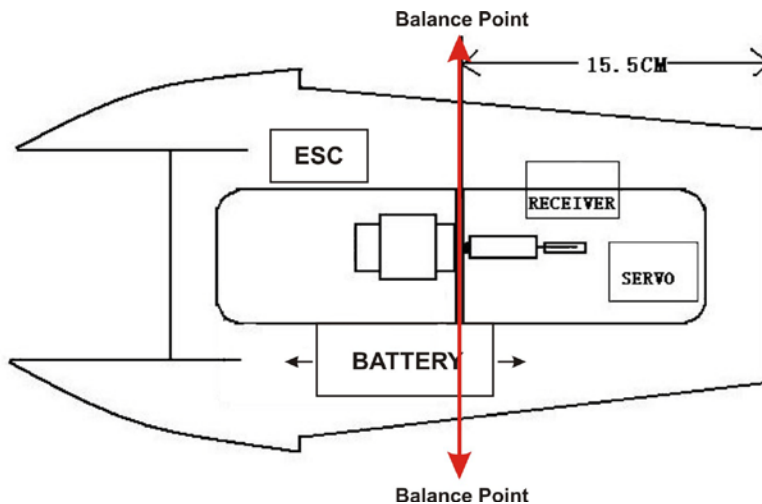

Adjust the battery fore and aft to obtain the balance point shown at 15.5cm – 6.1” from the stern of the boat.

A flexible shaft is used to connect the motor to the propeller. The motor is our specially designed MCR-280WC

water cooled brushless motor. Our MCR-40A brushless electronic speed control governs the speed and our high quality MCR-HPS high performance servo takes care of the steering. Our MCR-MHD outdrive system is machined from tempered aluminum and is available as a spare parts package.

The receiver, speed control, and battery must be protected from water intrusion. It is normal that a small amount of water will get into the boat each time it is run. The receiver and speed control can be placed in a small plastic bag or balloon and the opening rubber banded tightly shut. Immersing the ESC will void the warranty. The hatch is simply taped down with boat hatch tape included. Tape the sides first and then across at the front and back. Make sure the tape is well sealed. A small sponge can be placed inside the boat to soak up any small amounts of water. Place some Styrofoam in the front of the boat and/or under the side deck for flotation.

Hooking up the water cooling to ESC: disconnect the tubing from the discharge side of the motor (the tube that goes through the SIDE of the boat). Connect the short piece of tubing provided to the motor and then to the ESC. Reconnect the tube that goes through the side of the boat to the other end of the ESC.

Maintenance:

1. NEVER under any circumstances run the boat out of the water for any appreciable length of time.
2. Add lubricating oil to flexible shaft after every run. We use a 50/50 mixture of 30W oil and STP.
3. In order to avoid distortion of the hull, we suggest you remove the battery if the boat will be in storage without running for long periods of time.
4. Monitor the condition of the flex shaft. Lubricate frequently and replace as necessary after an extended number of runs.

WARRANTY: The Mini-Cat has a one year limited warranty on the hull, motor, outdrive, and ESC for defects in manufacturing and workmanship. Abuse of the boat by running into obstacles, applying more voltage or amperage to the motor and speed control than specified in the instructions, running out of the water, etc. will not be covered. Warranty is VOID if the ESC gets wet. Warranty is **VOID** if **ANY** propeller other than that sold by Mini Cat Racing USA for use on the Micro Hydro is used. In the case of warranty claims, you must contact Mini Cat Racing USA for a Return Merchandise Authorization (RMA). The boat must be returned to the place of purchase in its original packing box along with the original purchase receipt and \$19.95 for shipping. The dealer will send it to Mini-Cat Racing USA. Mini Cat Racing USA will determine if warranty conditions are met or not. Mini Cat Racing USA may elect to repair or replace the item. Note that *The hull is not available separately.*

Spare Parts Available:

MCR-280WC	*Brushless Motor	\$89
MCR-40AWC	*Electronic Speed Control	79
MCWS-HQS	Mini High Performance Servo	20
MCR-MHP	Propeller (package of two)	5 (4 different pitch sizes available) (32mm is standard)
MCR-MHD	Outdrive Set	49
MCR-MHFS	Flex Shaft	22 (old style w/drive dog. New style 4mm threaded)
MCR-MHS	Pushrod Seal w/bushing	1

Items Needed:

2 Channel radio system, 75mHz or 27mHz

Lithium Polymer Batteries. 1400-2200mAh 3S 11.1V We recommend Hyperion 25C batteries.

*water cooled

PLEASE BE RESPECTFUL OF WILDLIFE WHEN RUNNING YOUR BOAT!

ALWAYS DISCONNECT THE BATTERY AFTER RUNNING. STORING THE BOAT WITH BATTERY CONNECTED WILL DISCHARGE THE BATTERY BEYOND REPAIR!

Mini Cat

HOTTER THAN A PEPPER SPROUT!

Mini Cat Racing USA • Land O Lakes, FL • www.minicatracingusa.com